

Introduction

The ShoreGear 90BRI Voice Switch package contains:

- ShoreGear 90BRI Voice Switch
- Power cord
- Stick-on feet for surface installation
- Mounting Ears – attachable installation brackets
- Cable retainer for the Telco cable (metal bracket with a Velcro strap)

About the ShoreGear 90BRI

The SG-90BRI Voice Switch connects enterprise telephone extensions through an internal IP network, or to any central office (CO) ISDN BRI trunk line. The switch provides connectivity through:

- Two RJ-45 local area network (LAN) connectors
- Four RJ-45 ISDN BRI ports for connecting the switch to telephone company ISDN BRI lines
- One RJ-21X port (male) for connecting the switch to a telephone company punch-down block, patch panel, or 12-port harmonica connector
- One DB-9 (female), RS-232C maintenance port (19200 bps, 8 bits, no parity, 1 stop bit, no handshake) for serial communications
- One audio input port (3.5 mm stereo) for connecting to a music-on-hold source
- One audio output port (3.5 mm stereo) for connecting to a corporate paging system or night bell

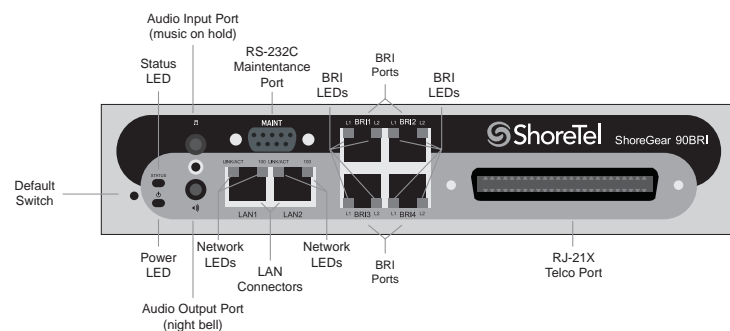

Installation Equipment

To install the switch, you need the following equipment:

- AC surge protector for the power connection
- RJ-45 cables for connecting the switch to the local area network and telco lines
- Music-on-hold source with a standard mini-headphone Y-adaptor (optional)
- Permanent earthing connector for grounding the device
- RJ-21 telephone cable (female on end connected to ShoreGear voice switch) for analog port connections
- RJ-21 to RJ-11 patch panel for connecting telephones and trunk lines
- #1 Phillips screwdriver

Installation Location Requirements

To ensure optimum operating conditions for the SG-90BRI voice switch, verify the operating environment is adequately ventilated, free of gas or airborne particles, and isolated from electrical noise.

Installation

Installing the ShoreGear 90BRI in a 19-inch Rack

The SG-90BRI is placed in a 19-inch rack only by mounting a ShoreGear Dual Tray into the rack, then installing the SG-90BRI into the Tray.

Refer to the *Quick Install Guide for the ShoreGear Dual Tray for Tray installation instructions and information on using the Tray.*

Mounting the ShoreGear Voice Switch on a Flat Surface

If you plan to mount the switch on a flat surface, first attach the provided rubber feet to the bottom corners of the device. (You can stack up to three switches in a surface installation.)

German: Das ShoreGear Voice-Schaltgerät auf einer ebenen Oberfläche montieren

Wenn Sie planen, das Gerät auf einer ebenen Oberfläche zu montieren, befestigen Sie zunächst die mitgelieferten GummifüÙe an den unteren Ecken des Geräts. (Bei einer Oberflächeninstallation können Sie bis zu drei Schaltgeräte übereinander stapeln.)

Attaching an Earthing Connector

To meet electrical safety requirements for proper grounding, you must connect a permanent earthing protector between the ShoreGear voice switch and the wiring system ground.

1. Connect a ground wire (#14 AWG wire or larger) to the screw on the back of the unit and to the right of the product label.
2. Connect the other end of the ground wire to the wiring system ground.

CAUTION: Always connect the permanent earthing connector before attempting to connect the switch to a LAN segment and telecommunication lines.

German: Einen Erdungsleiter anschließen

Um den elektrischen Sicherheitsanforderungen für eine korrekte Erdung nachzukommen, müssen Sie einen permanenten Erdungsschutz zwischen dem ShoreGear-Gerät und der Erde des Kabelsystems installieren.

1. Schließen Sie ein Erdungskabel (Nr. 14 AWG oder größer) an die Schraube an der Rückseite des Geräts an, die sich rechts neben dem Produktetikett befindet.
2. Schließen Sie das andere Ende des Erdungskabels an die Erde des Kabelsystems an.

VORSICHT: Schließen Sie immer zuerst den permanenten Erdungsschutz an, bevor Sie versuchen, das Gerät an ein LAN-Segment und Telekommunikationsleitungen anzuschließen.

Servicing Procedures

WARNING: The SG-90BRI contains no internal field serviceable parts. Return the equipment to ShoreTel for any required service procedures.

CAUTION: Internal fuses should be serviced only by qualified ShoreTel personnel. If internal fuses are blown and require replacement, return the SG-90BRI to ShoreTel for service.

Connections and Servicing

Connecting the ShoreGear Voice Switch to the Network

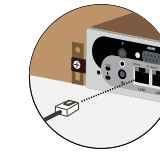

Once the ShoreGear 90BRI Voice Switch is secured to a rack or surface-mounted, you can connect it to the data network. Use an RJ-45 Ethernet cable to connect one or both of the LAN ports to the network subnet.

While both ports can detect and respond to link status, the switch uses only one LAN port at a time.

Powering on the ShoreGear Voice Switch

After connecting the switch to the network, power on the device by connecting it to an AC power source.

1. Plug an AC surge protector (not provided) into a grounded AC power source.
2. Plug one end of the provided power cord into the receptacle on the back of the switch, then plug the other end into the AC surge protector.

The power LED flashes momentarily, and remains lit.

- If the LED is not lit, make sure the power cord is plugged into the switch and the power source.
- If the LED continues flashing, there is an internal error. Unplug the switch to power it off, then power it back on. Refer to the “Configuring Switches” chapter in the **ShoreTel Administration Guide** for information on flash patterns, or contact the ShoreTel Support Services at <http://www.shoretel.com>.

The LAN ports auto-sense the network transport rate. When the network connection is established, the network LED indicates a transport rate of 10 Mbps or 100 Mbps, and whether the switch is receiving and transmitting data.

Optional Connections

After connecting the voice switch to the LAN, you can make optional connections, including input from a music-on-hold source or output to an internal paging system.

1. Connect a music-on-hold source (CD player or other audio source) to the audio input port.
2. Connect your site's paging system to the audio output port.

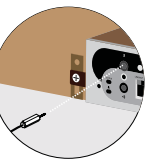

Connecting Trunk and Telephone Lines

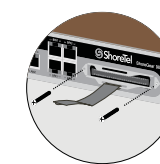

Use the provided cable retainer to connect the voice switch to the telephone company's punch-down block or patch panel.

1. Use a #1 Phillips screwdriver to remove the two screws on either side of the RJ-21X port, then place the retainer on the port and re-attach the screws.
2. Plug the Telco cable into the port, then pull the Velcro strap tightly around the cable connector and fasten it.
3. Connect the other end of the Telco cable to the punch-down block or patch panel.
4. Use RJ-45 cables to connect your ISDN BRI lines to the telco ports.

CAUTION: To reduce risk of fire, use only No. 26 AWG or larger (e.g., 24 AWG) UL Listed or CSA Certified Telecommunication Line Cord

For detailed information on switch port and trunk configuration, see the “Configuring Switches” and “Configuring Trunks” sections in the *ShoreTel Administration Guide*.

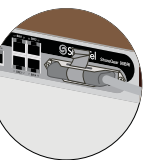

ShoreGear 90BRI Voice Switch RJ-21X Port Pinout

An RJ-21 telephone cable, wired straight through, allows the ShoreGear 90BRI Voice Switch to connect to a standard 12-port patch panel or 12-port harmonica block. When connecting to a 24-port patch panel, the voice switch's four analog extension ports map to alternating ports from port 17 through 23 on the patch panel.

Pin No.	1	2	3	4	5	6	7	8	9	10	11	12	13	14	15	16	17	18	19	20	21	22	23	24	25
Port No.																	9	10	11	12					X
Port Type																	E	E	E	E					X
Pin No.	26	27	28	29	30	31	32	33	34	35	36	37	38	39	40	41	42	43	44	45	46	47	48	49	50

Pin pairs	Assignment
17,42 19,44 21,46 23,48	Four configurable ports (E) for telephones.

Network Configuration

Once the ShoreGear voice switch is installed and powered on, it must be configured for network operations. A voice switch gets a network configuration by assignment from a DHCP or BOOTP server, or directly from an administrator console (see procedure below).

For more information on setting up a switch for automatic configuration by a DHCP or BOOTP server, see the ShoreTel Planning and Installation Guide.

Configuring the Voice Switch from a Console

1. Use a straight-through serial cable, DB9 male to DB9 female, to connect the switch to a console PC.
2. On the PC or laptop, start a terminal emulation program and connect to the voice switch using these serial communication settings: 19200 bps, 8 data bits, no parity, one stop bit, no handshake.
3. At the ShoreTel login prompt, press ENTER to display the Switch Options menu.
4. Type 3 and press ENTER to display a menu of configuration options.
5. Choose Menu Options and follow the onscreen instructions for setting network parameters, including IP address, subnet mask, and gateway.

Specifications

Feature	Specification
Dimensions	1.69 x 8.39 x 14.88 inches (43 x 213 x 378 mm)
Weight	5.3 lb (2.4 kg)
Input voltage	100-240 VAC, 50-60 Hz
Power consumption	1A max.
Humidity	0-90% relative humidity (non-condensing)
Operating temperature	0-50° C

Power LED

The power LED indicates the operating status of the switch.

Light	Description
Steady	The switch is powered on, and the internal software is running.
Flashing	Two flashes indicates a failed internal self-test (i.e. hardware failure). Refer to "Configuring Switches" in the ShoreTel Administration Guide for details on other flash patterns.
Off	The switch is not powered on, or the software is not running.

Status LED

The status LED provides voice switch activity information.

Color	Activity	Description
Off		No ports are assigned
Green	Steady	No ports are handling active calls
Green	Flashing-Fast	At least one port is handling an active call.
Yellow	Steady	No ports are handling active calls and at least one port is out of service.
Yellow	Flashing-Slow	The switch is not connected (or has lost connection) to a ShoreTel server.
Yellow	Flashing-Fast	At least one port is handling an active call and at least one port is out of service.

Network LEDs

Each LAN connector provides two LEDs (Link/Act and 100) that indicate the activity and communication speed of the connected network

LED	Color/State	Description
Link/Act	Off	This switch cannot detect an Ethernet network.
Link/Act	Green-Steady	This switch is connected to an Ethernet network.
Link/Act	Green-Flashing	This switch detects network data traffic.
100	Off	Network interface is operating at 10 Mbps.
100	Green	Network interface is operating at 100 Mbps.

BRI LEDs

Each BRI connector provides two LEDs that indicate port activity.

LED L1	LED L2	Description
Off	Off	Port not configured in ShoreWare Director
Yellow	Off	Port inactive or not connected
Green	Off	Layer 1 active. Layer 2 not established
Green	Green	Layer 1 active. Layer 2 active
Green	Flashing Green	Layer 1 active. Layer 2 active. Call in progress (Layer 3 active).



ShoreGear 90BRI Voice Switch

Quick Install Guide

